

# In-line FOUP monitoring

## APA 302

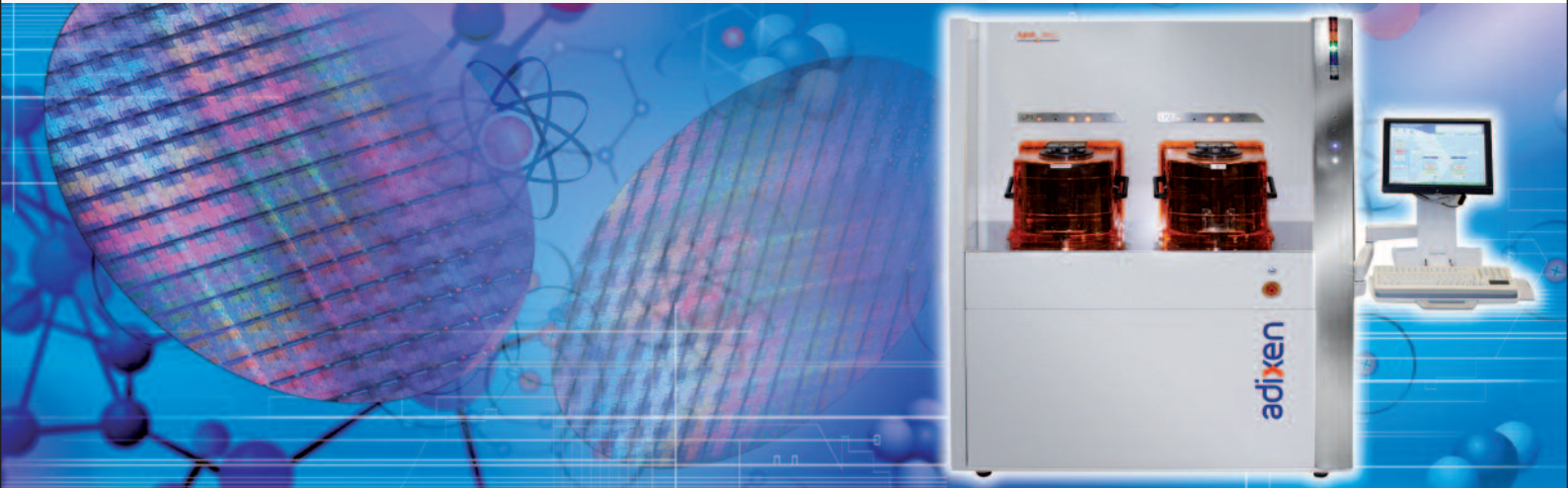

### AIRBORNE MOLECULAR CONTAMINATION TRACKING

Sub-ppbv levels of contamination such as acids, can degrade process performance and decrease product yield.

"Fab Airborne Molecular Contamination (AMC) requirements have been defined, but AMC at the equipment and FOUP level needs to be understood and defined" as stated by the ITRS.

#### REAL-TIME

The APA 302 (Adixen Pod Analyzer) is a unique in-line FOUP AMC monitoring solution to:

- Detect in 2 mn and characterize at FOUP and wafer level,
- Improve understanding of the wafer environment,
- Provide real time data to optimize cleaning techniques.

➤ **Throughput of APA 302 with OHT (Overhead Hoist Transport) option > 16 FOUP / h.**

#### HIGH SENSITIVITY

In order to identify multiple AMC compounds, the system combines state of the art gas detection technology, such as Ion Mobility Spectroscopy, Flame Ionization Detection or Fluorescence UV.

➤ **To verify its performance, APA 302 includes an autocalibration unit which can be activated periodically.**

#### NO FOUP MODIFICATION NEEDED

APA 302 advanced interface allows safe automatic sampling directly inside production FOUps (F300, A300...).

➤ **AMC monitoring can be performed with loaded or unloaded FOUps.**

#### APPLICATIONS

- Strategies for yield improvement
- Storage optimization
- Cleaning Qualification

**adixen**

## Analyzer performances

Analyzer	Scale	Limit of detection	Response time within 2 min
NH3*	0 - 200 ppbv	< 0.2 ppbv	> 80 %
Total amines*	0 - 200 ppbv	< 0.2 ppbv	> 80 %
Total acids*	0 - 200 ppbv	< 0.2 ppbv	> 90 %
SO <sub>2</sub>	0 - 500 ppbv	< 0.5 ppbv	> 85 %
H <sub>2</sub> O	0 - 100 % RH	5 %	> 90 %
Total Volatile Organics	0 - 99 ppmv	< 25 ppbv	> 90 %

\* Based on IMS technology, includes Ni63 source (< 0,005 microcuries) • Other options availables : please contact us

## Software System (for local Operation)

### The user friendly interface features:

- Real Time graphical Software(Pod & Clean room Ambient)
- Adjustable alarm limits
- Data saving and treatment query (specific algorithms)
- Automatic Calibration Mode
- Generate reports

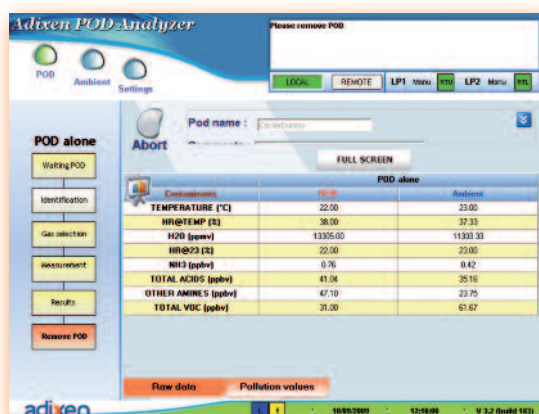

## General Specifications

Operating temperature	18 – 25 °C	
Operating area	Clean room (up to 1000 class )	
Humidity	30 – 50 % HR	
Noise level	< 70 dBA	
Nominal voltage	110 or 240 Vac, 9-4 A max by internal switch	
Frequency	50 – 60 Hz	
Maximum power consumption	~1 kW	
Compressed Dry Air	Specifications	CDA dry (<-40°C dew point) 1/8" gas fitting (female)
	Pressure	Between 5-10 bar at APA inlet
DI-Water for Total Volatile Organics	Specifications	Conductivity lower than 0.30 µS/cm (0.15 mg/l)
	Pressure	Between 1.8 – 2.1 bar
FAB Communication	SEMI GEM 300	

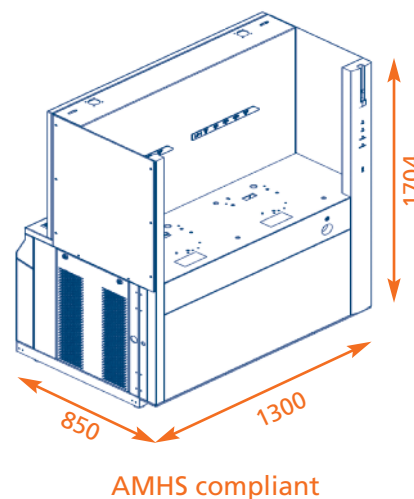

### Alcatel Vacuum Technology France

98, avenue de Brogny - BP 2069 - 74009 ANNECY CEDEX - FRANCE - Tel.: (33) (0) 4 50 65 77 77 - Fax: (33) (0) 4 50 65 77 89  
[www.adixen.com](http://www.adixen.com)

<b>China</b> Alcatel Vacuum Technology Shanghai Tel: (8621) 5027 0628 Fax: (8621) 3895 3815	<b>France (Headquarters)</b> Alcatel Vacuum Technology France Tel: 33 (0)4 50 65 77 77 Fax: 33 (0)4 50 65 77 89	<b>Germany</b> Alcatel Hochvakuum Technik GmbH Tel: (49) 9342 96 10 0 Fax: (49) 9342 96 10 30	<b>India</b> Alcatel Vacuum Technology India Tel: (91) 124 473 7777 Fax: (91) 124 473 7799	<b>Italy</b> Alcatel Vacuum Systems S.p.A. Tel: (39) 039 686 3855 Fax: (39) 039 667 125	<b>Japan</b> Alcatel-Lucent Japan Ltd Tel: (81) 3 6431 7130 Fax: (81) 45 544 0049	<b>Korea</b> Alcatel Vacuum Technology Korea Tel: (82) 31 206 6277 Fax: (82) 31 204 6279
<b>Netherlands</b> Alcatel Vacuum Technology Netherlands Tel: (31) 345 478 400 Fax: (31) 345 531 076	<b>Singapore</b> Alcatel-Lucent Singapore Tel: (65) 6254 0828 Fax: (65) 6254 7018	<b>Sweden</b> Alcatel Scandinavia Tel: (46) 13 35 59 00 Fax: (46) 13 35 59 01	<b>Taiwan</b> Alcatel Vacuum Technology Taiwan Tel: (886) 3 5599 230 Fax: (886) 3 5599 231	<b>United Kingdom</b> Alcatel Vacuum Technology (U.K.) Ltd Tel: (44) 1 506 418 000 Fax: (44) 1 506 418 002	<b>USA</b> Alcatel Vacuum Products Tel: (1) 781 331 4200 Fax: (1) 781 331 4230	